



PH660 Radio

MAINTENANCE MANUAL

(Level1) V1.0

PH660 Radio Maintenance Manual (Level1) V1.0

Version	Date	Author	Update	Remarks
V1.0	2020/4/3			

© 2020 Copyright Caltta Technologies Co.,Ltd. All rights reserved

Copyright statement:

The copyright of this document belongs to Caltta Technologies Co.,Ltd. Text contains proprietary information owned by Caltta Technologies Co.,Ltd., without the written permission of Caltta Technologies Co.,Ltd., any unit or individual shall not use or leak any document and pictures, this document contains tables, picture, data and other information.

The information in this document contains the development progress of Caltta Technologies Co.,Ltd. products and technology will continue to update, Caltta Technologies Co.,Ltd. would not notice such information updates.

CONTENTS

1 Overview.....	1
1.1 Appearance.....	1
1.2 Standard Package.....	1
1.3 Specification.....	2
2 Function Test.....	4
2.1 Basic Function Test.....	4
2.2 Check Firmware Version and Device Information.....	4
3 Software Upgrade.....	5
3.1 Before Upgrade.....	5
3.2 Upgrade Procedure.....	6
3.3 CPS Software.....	14
4 Radio Disassemble Demonstration.....	23
4.1 Tools.....	23
4.2 Procedure.....	24
4.3 Disassemble Steps.....	24
4.4 Assemble Steps.....	34
4.5 Components.....	35
5 Hardware Pictures.....	36
5.1 Front of Main PCB.....	36
5.2 Back of Main PCB.....	37
6 Troubleshooting Maintenance Flow.....	38
6.1 Structural Part Failure.....	38
6.2 Battery Failure.....	39
6.3 No Power On.....	40

6.4 Radio Freeze or Power Off Automatically.....	41
6.5 Charge Failure.....	42
6.6 No Voice (MIC) Failure.....	43
6.7 No Sound (Speaker) Failure.....	44
6.8 Side Key Failure.....	45
6.9 Keypad Failure.....	46
6.10 Accessory Failure.....	47
6.11 TF Missing.....	48
7 Check After Maintenance.....	49
7.1 Check Latest Firmware Version and Device Information.....	49
7.2 Function Check.....	49

1 Overview

1.1 Appearance



Note:

This picture is for reference only, please refer to the actual product.

1.2 Standard Package

SN	Item	Quantity (PCS)
1	PH660 Radio Unit	1
2	Battery	1
3	Power Adapter	1
4	Quick Start Guide	1
5	Antenna	1
6	Belt Clip	1
7	Charger	1

1.3 Specification

General	
Frequency	UHF1: 400-470MHz VHF:136-174MHz
Channel Capacity	1024
Zone Capacity	64 (maximum 32 channels per zone)
Channel Spacing	12.5kHz/20KHz/25KHz
Frequency Stability	±0.5ppm
Operating Voltage	7.4V
Battery Capacity	2600mAh (Standard) / 2000mAh (Optional)
Battery Life(5:5:90)	Analog: 16 hours Digital: 20hours
Size (H x W x D)	100*54.5*36.5mm (Without Antenna)
Weight	About 290g (With Antenna and Battery)
Screen	1.75' Transflective LCD, 240×180, 4 Lines Text
Vocoder	AMBE++
Bluetooth	Support BT2.1+EDR/4.0 (Optional)
Location	GPS (Optional)
Man down	Support
Vibration	Support
TF Card	Support
Real-time Clock	Support
Encryption	Support SW and HW Encryption (Optional)
Receiver	
Sensitivity(Analog)	0.22uV(12dB SINAD)
Sensitivity(Digital)	0.22uV (5% BER)
Adjacent Channel Selectivity	60 dB@12.5KHz/70 dB@20/25KHz (TIA603A) -1T
	45dB@12.5KHz /70 dB@20/25KHz (TIA603D) -2T
	60dB@12.5KHz /70 dB@20/25KHz (ETSI)
Intermodulation	70 dB (TIA603D)
	65 dB (ETSI)
Spurious Rejection	70 dB (TIA603D)
	70 dB (ETSI)
Blocking or Desensitization	80dB(TIA603D)
	84dB(ETSI)
Co-channel Rejection	-12~0 dB @12.5KHz/-8~0 dB @20/25KHz
Hum and Noise	-40 dB@12.5KHz /-43 dB@20KHz /-45 dB@25KHz
Rated Audio Power	0.5W
Max Audio Power	2.0W

Audio Distortion @ Rated Audio	≤3% (Typical)
Audio Response	+1~-3dB (TIA603D)
Conducted Spurious Emission	-57 dBm (TIA603D)
Transmitter	
Low Power Output	1W
High Power Output	4W (UHF1)/5W(VHF)
FM Modulation	12.5KHz: 11K0F3E / 20KHz: 14K0F3E / 25KHz: 16K0F3E
4FSK Digital Modulation	12.5KHz Data Only: 7K60F1D&7K60FXD
	12.5KHz Voice Only: 7K60F1E&7K60FXE
	12.5KHz Voice And Data: 7K60F1W
Conducted/Radiated Emission	-36dBm ≤1GHz ; -30dBm >1GHz
Modulation Limiting	±2.5KHz @12.5KHz /±4KHz @20KHz /±5.0KHz @25KHz
FM Hum and Noise	-40 dB@12.5KHz /-43dB@20KHz /-45 dB@25KHz
Adjacent Channel Power	60 dB@12.5KHz /70 dB @20/25KHz
Audio Distortion @ Rated Audio	≤3% (Typical)
Audio Response	+1~-3dB(TIA603D)
Environmental	
Operating Temperature	-30°C ~ +60°C
Storage Temperature	-40°C ~ +85°C
ESD	IEC 61000-4-2 (level 4) ±8kV (Contact) ±15kV(Air)
Dust and Water Resistance	IP68
Reliability	GJB 150A-2009 and MIL-STD-810 C/D/E/F/G
BeiDou/GPS	
Accuracy specs are for long-term tracking (95th percentile values>5satellites visible at nominal -130 dBm signal strength)	
TTFF (Time To First Fix) - Cold Start	<60s
TTFF (Time To First Fix) - Hot Start	<10s

Horizontal Accuracy	<10m
---------------------	------

2 Function Test

2.1 Basic Function Test

Item	Test Method and Requirements	Component Involved
1.Basic requirement	1. Radio accessories complete. 2. No dismantle label complete. 3. Waterproof label no discoloration. 4. No physical damage. 5. Within the warranty period.	None
2.Failure Re-present	1. Radio with the battery can power on normally. 2. Detect the fault according to the customer description to confirm if it can be re-presented.	Radio Unit, Battery
3.Function Test	1. Test the PTT call to confirm the function is normal. 2. Connect the matching earpiece with the radio to confirm it can transmit and receive voice normally and the actual voice quality is good.	Earpiece, Battery
4.Charging Test	Connect the matching charger to confirm it can charge.	Charger, Battery

Note:

For other items that cannot be detected in steps (1) to (4), please refer to the radio user manual. If a fault is found in one step, the subsequent detection steps are suspended as the radio is treated faulty.

2.2 Check Firmware Version and Device Information

Check the firmware version and device information as below:

- 1) Go to the home screen;

- 2) Press OK button to enter the main menu and choose Device Info;
- 3) Check the firmware version, DSP version, RCDB version, frequency range and serial number, etc.

Or get the device information by reading through CPS. You can contact after sales to get version comparison table.

Basic Information	
Model Name	PH660
Serial Number	1234567890
Model Type	Portable
Model Number	PH660-GMBD00000000-U1-C
Frequency Band[MHz]	400-470
Firmware Version	V3.06.05.B1
RCDB Version	D3.06.016
DSP Version	V3.06.05.B2A
Bootloader Version	V3.06.002
Bluetooth Version	V2.02
Last Programming Date	2020-02-21,15:59

3 Software Upgrade

3.1 Before Upgrade

1. Get the one-click upgrade software for the target version.
2. Prepare the radio to upgrade, take away the cover of accessory interface on the side.
3. Prepare the data cable (Type: AP340). Connect its USB port to your computer USB port, connect the other side to your radio accessory interface port and fasten it.

AP340 Data Cable:



3.2 Upgrade Procedure

1. Install the upgrade software package

1) Click to open the upgrade software, choose the language according to your requirement (Cn for Chinese, En for English);



2) Double click setup.exe in the chosen language folder;



3) Click Next in the below interface;

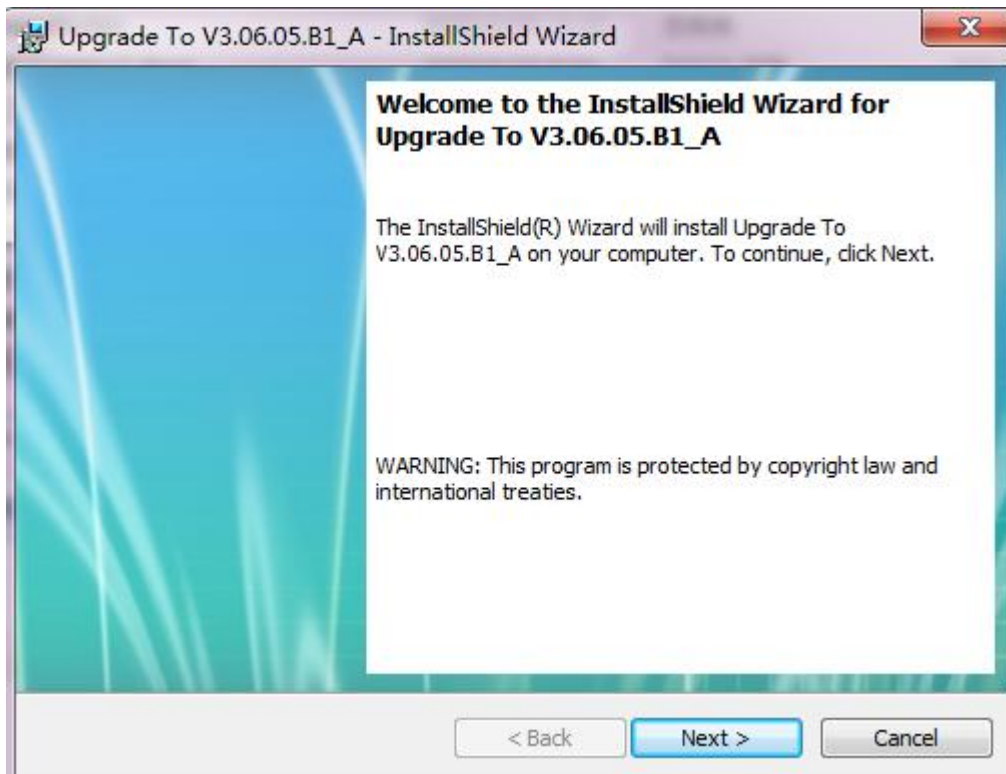

4) Select 'I accept' and click Next in the below interface;



5) Select Complete and click Next if you use the default installation path;

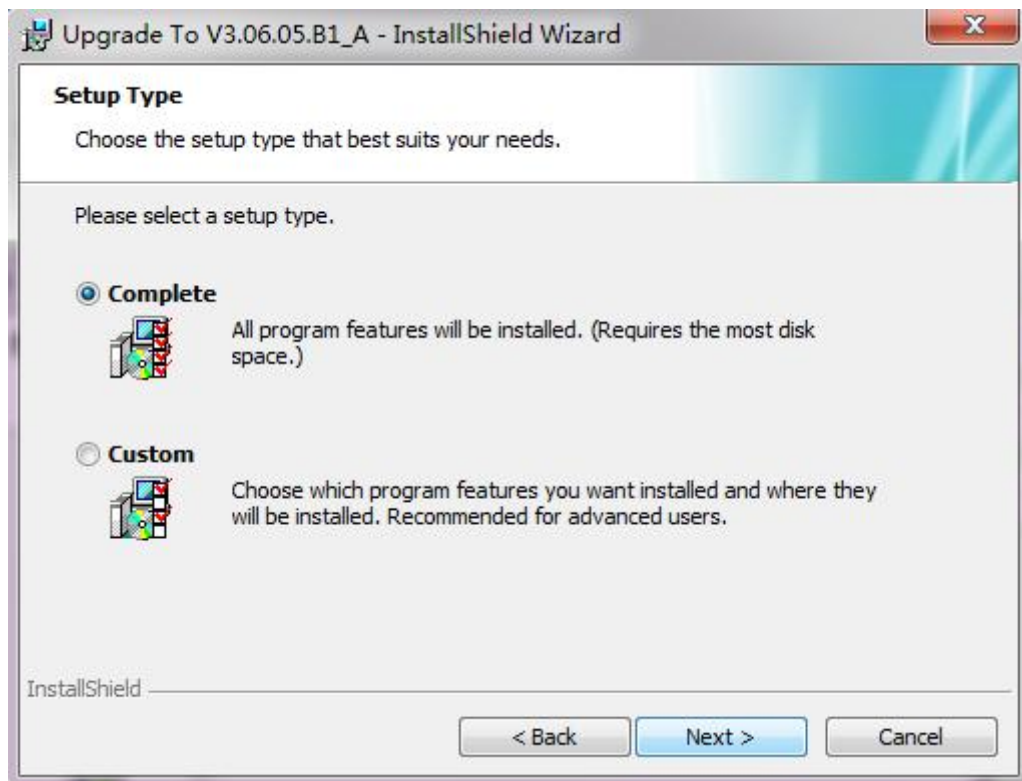

Select Custom and click Next if you choose your own installation path;

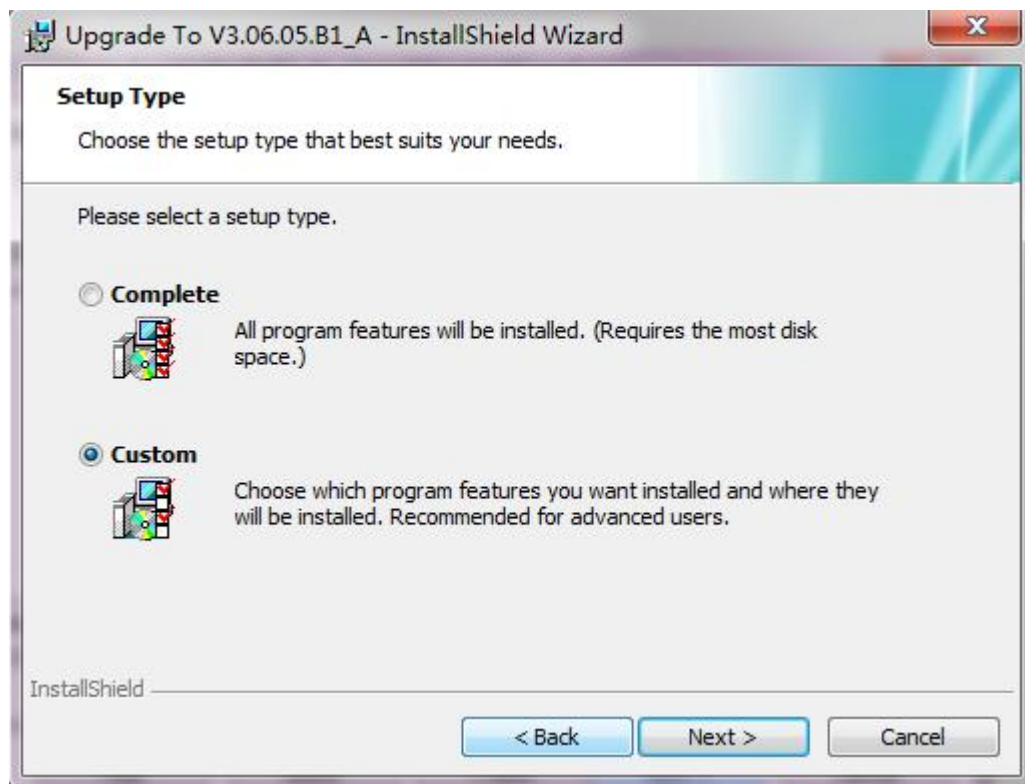

Click Change to modify the installation path, then click Next;

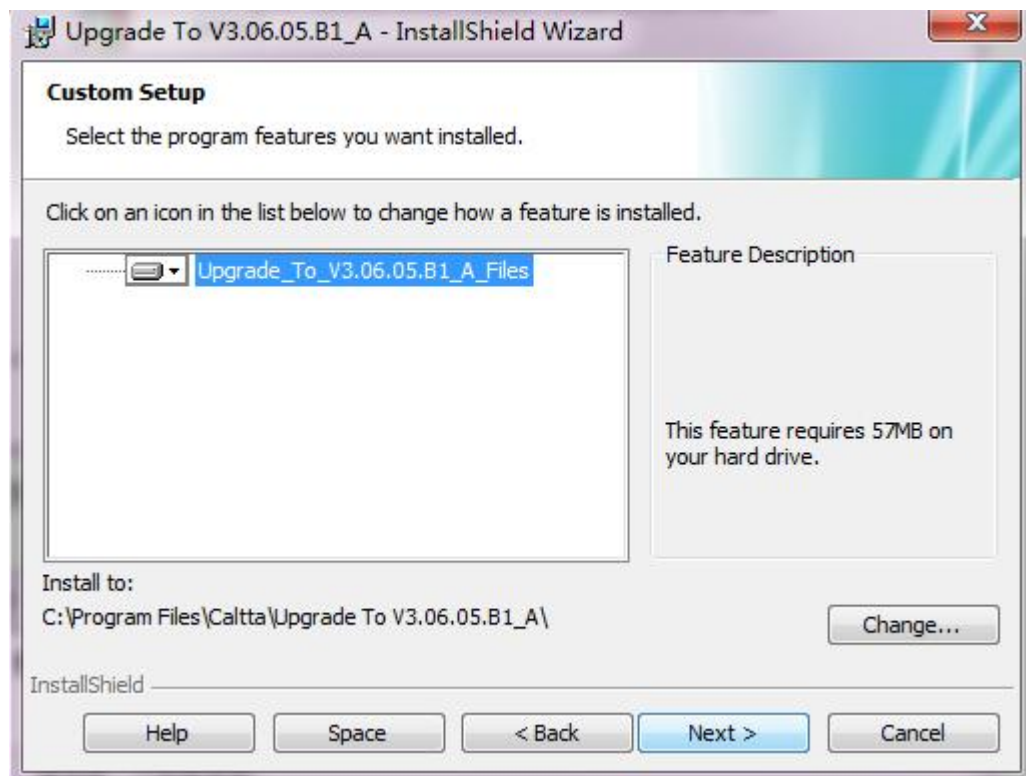

6) Click Install to confirm installation.

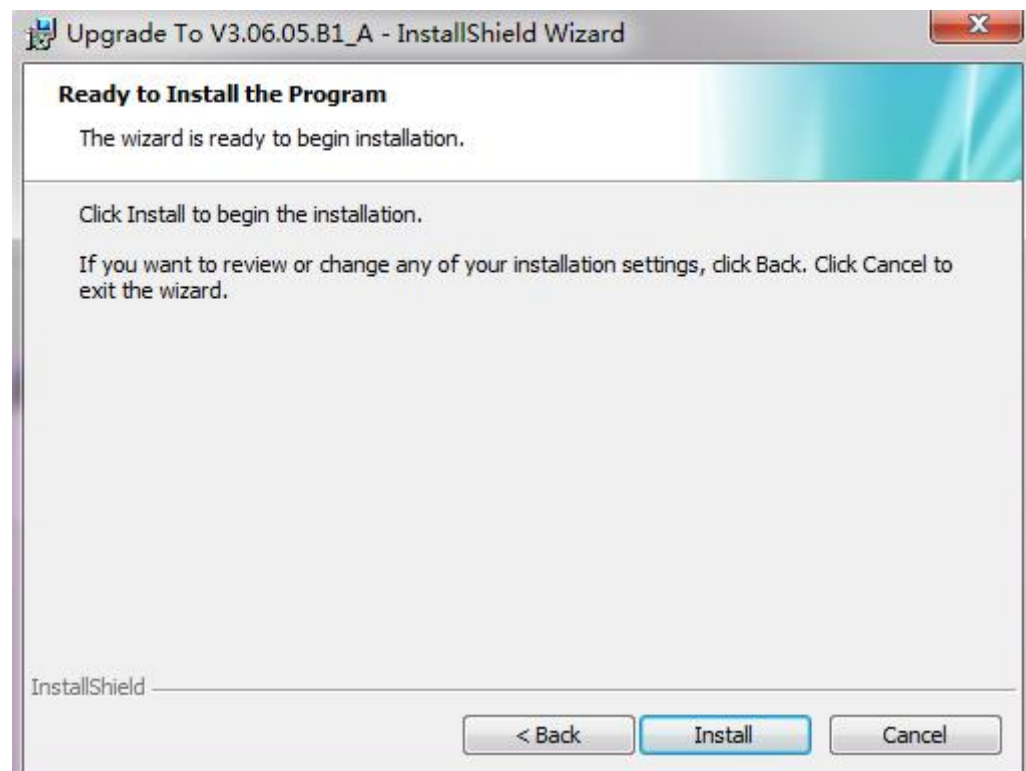

7) Wait the installation to complete. Click Finish to end one-click upgrade procedure.

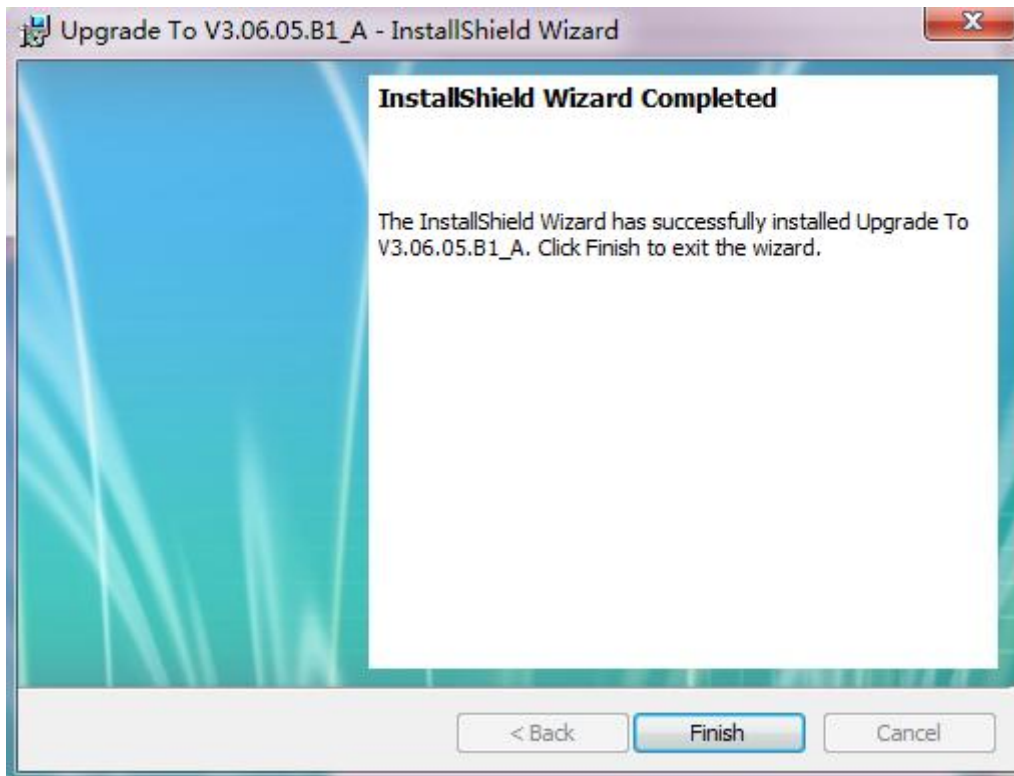

8) An icon will be on desktop after installation.



2. Radio Upgrade

- 1) Connect the radio to the PC through the data cable;
- 2) Double click the upgrade tools icon to run it;
- 3) The radio enters into the flash burn mode, press the PTT button and TK button (on the top) at the same time, and rotate the volume knob to power on the radio, the radio enters into the upgrade mode;



The LED indicator glows green:



4) After the upgrade software detects the USB port and displays it, you can select the corresponding USB port and click to upgrade.

5) You can choose Chinese or English language, and choose if preserve the current setting data when upgrade the radio.

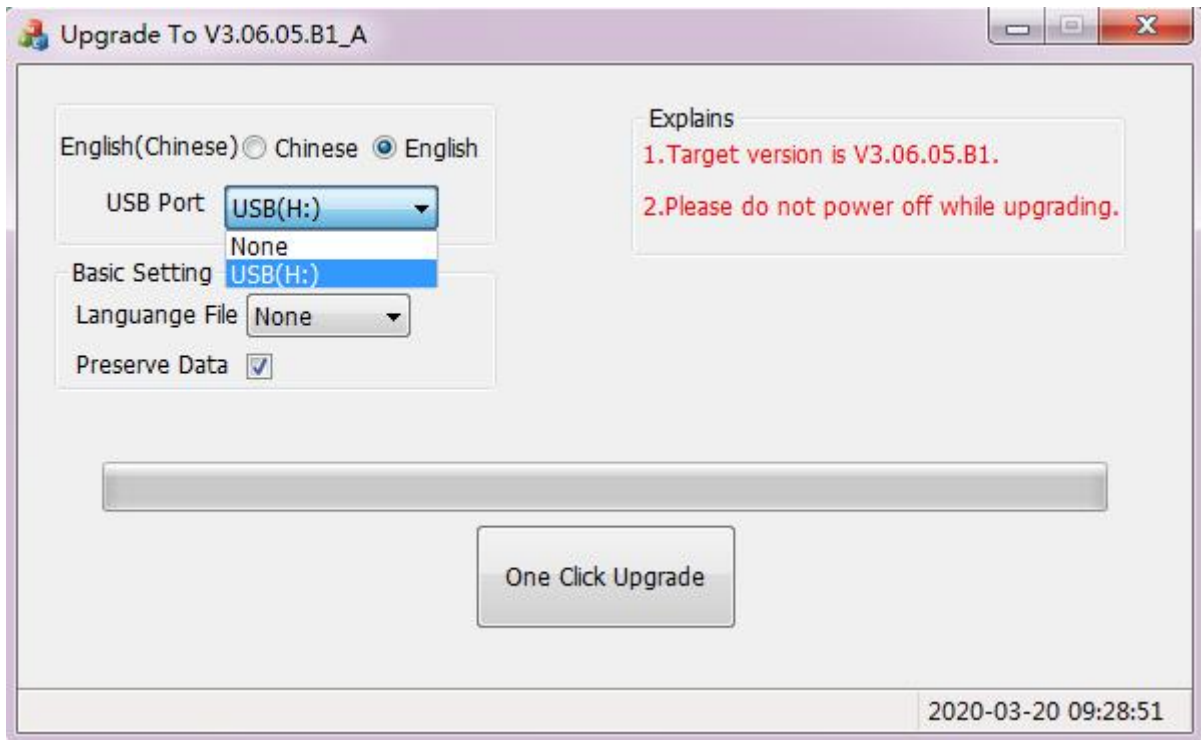

6) The LED indicator flashes green during the upgrade, the radio displays the following interface:

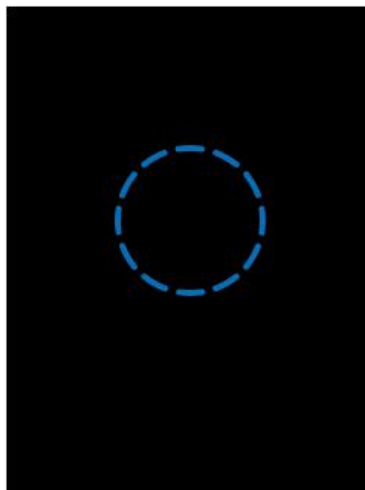

7) Upgrade complete prompt;

After upgrade completes, the software tools will display as below:

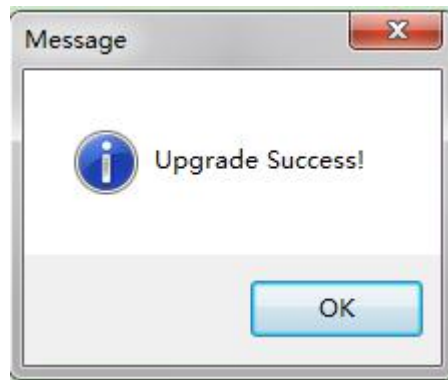

Note:

- *Don't power off the radio during the upgrade.*
- *If upgrade fails, please repeat the upgrade procedure.*

8) Reboot the radio after upgrade to check if the firmware is the target version.

3.3 CPS Software

1. CPS Software Installation Procedure

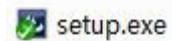

- 1) Start installation, double click  to install;
- 2) Click Next following the prompt.

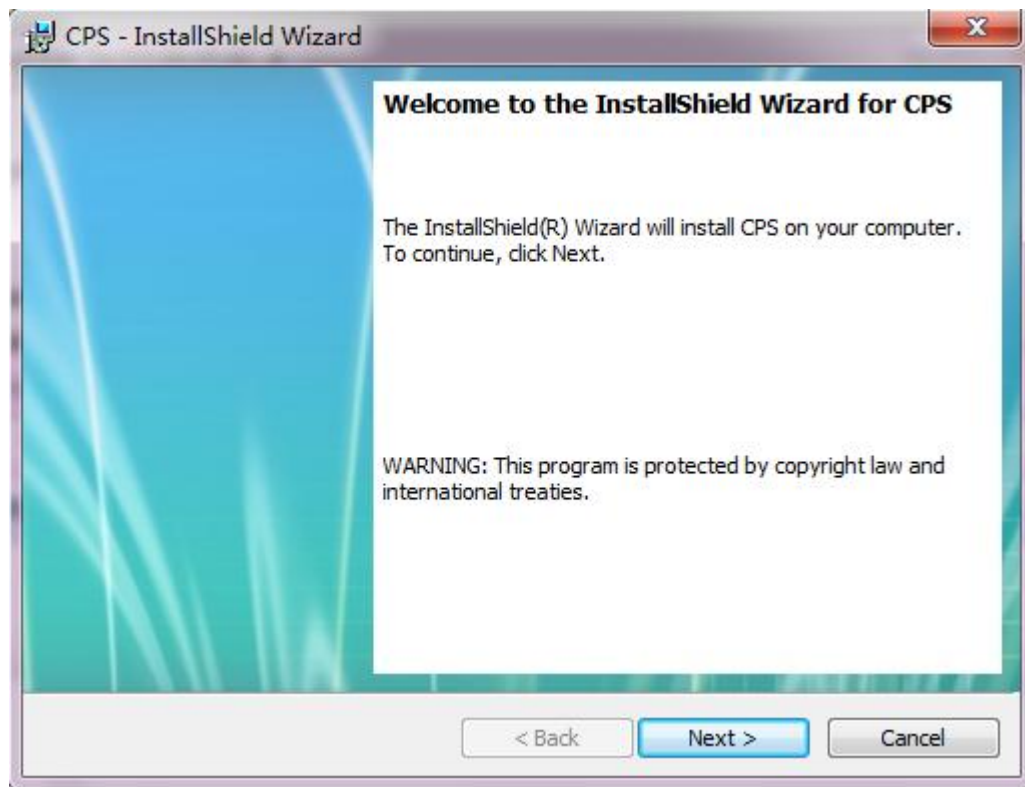

3) Select 'I Accept' and click Next.

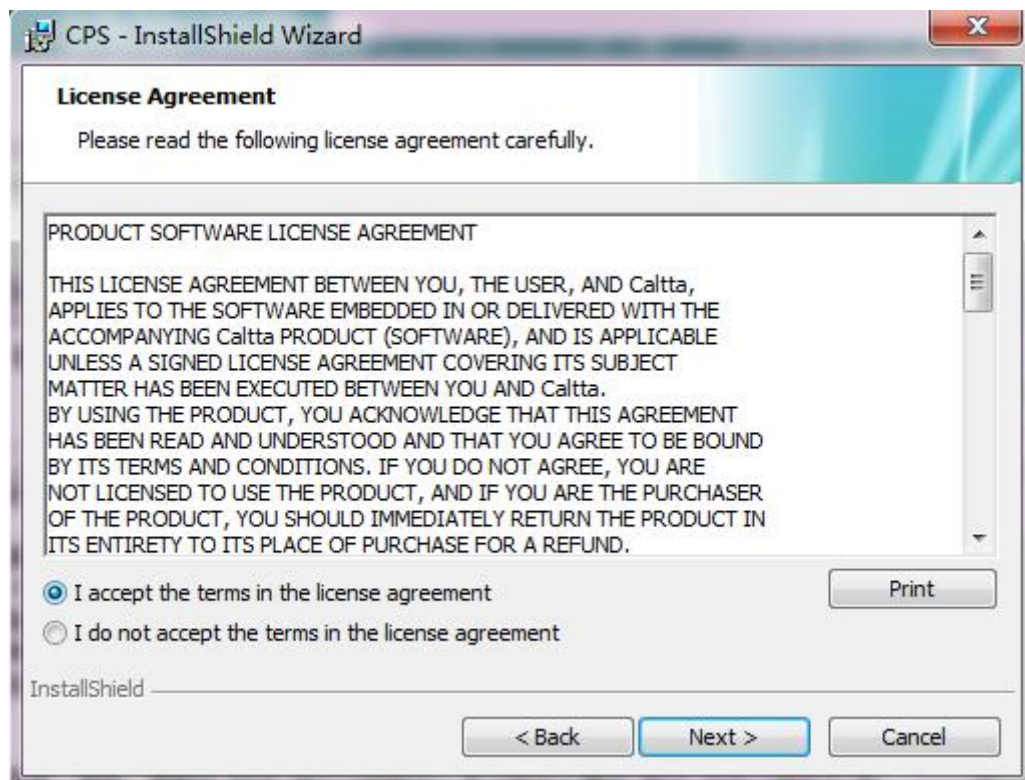

4) Select Complete and click Next if you use the default installation path.

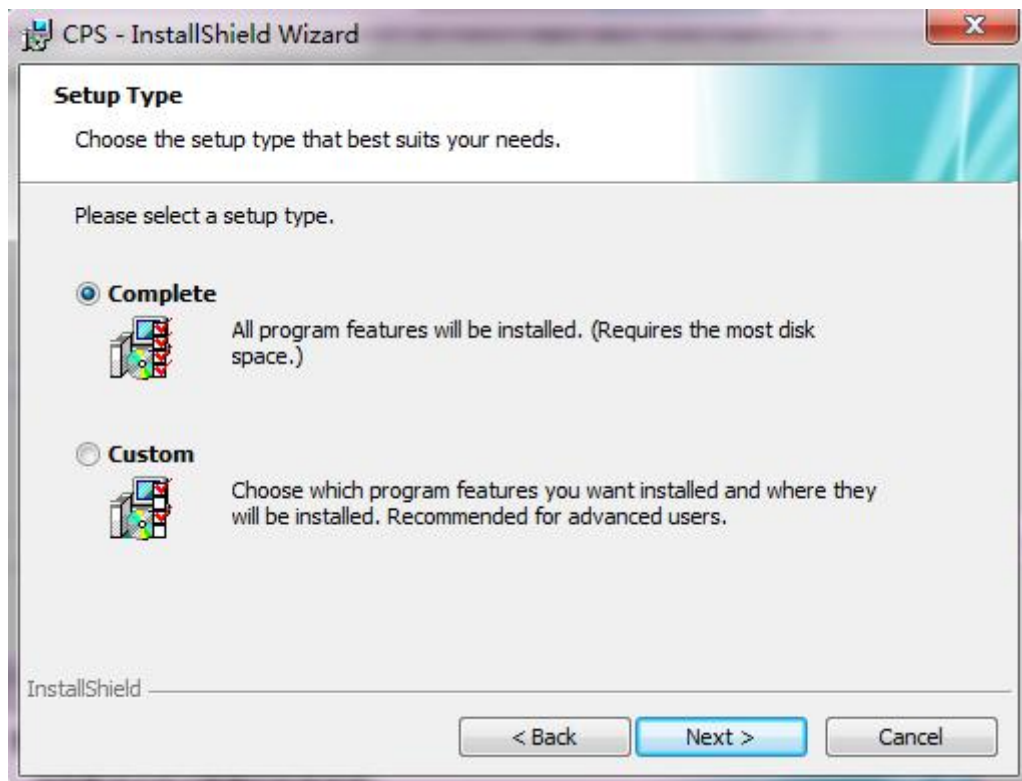

Select Custom and click Next if you choose your own installation path.

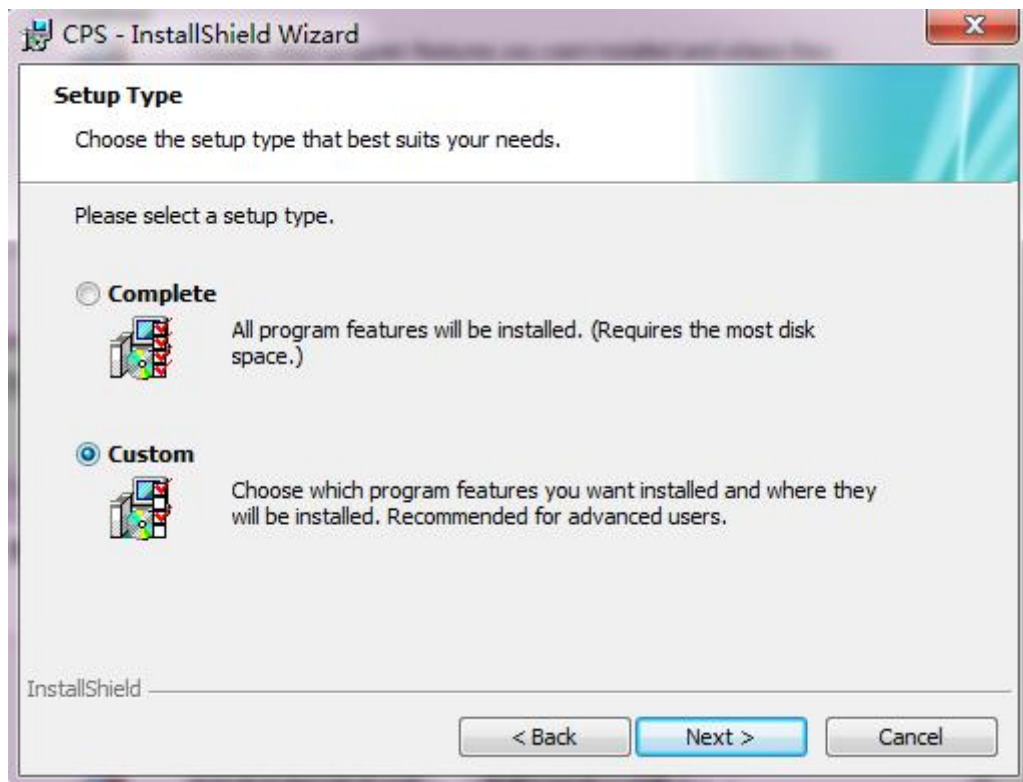

Click Change to modify the installation path, then click Next.

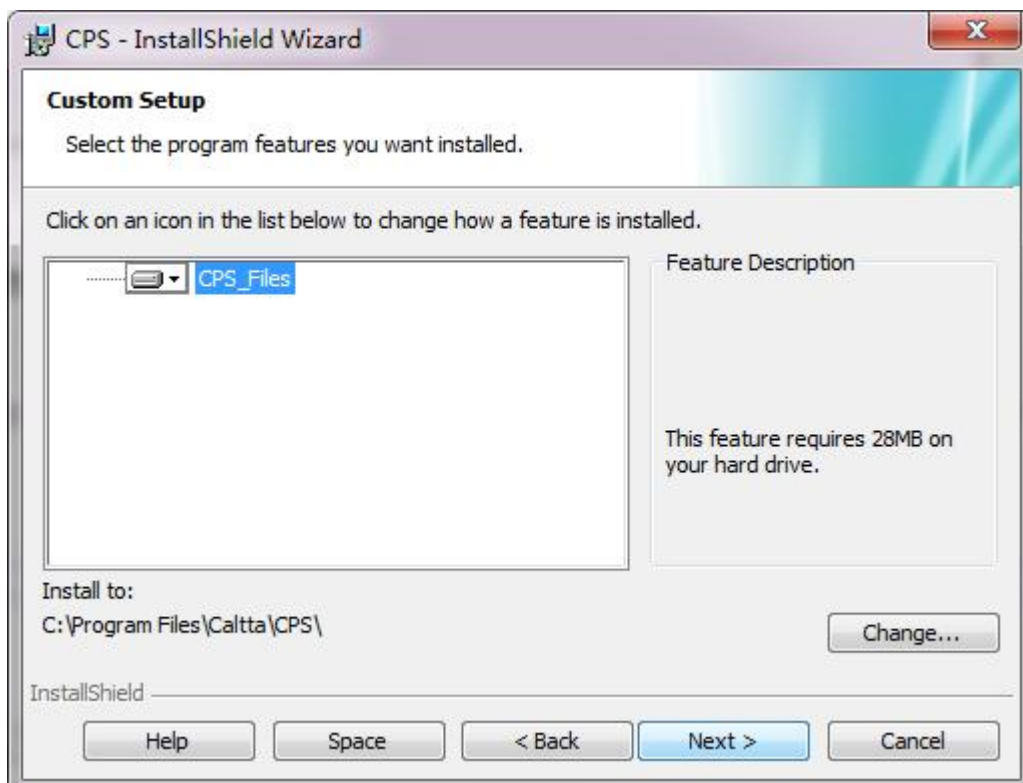

5) Click Install to confirm installation.

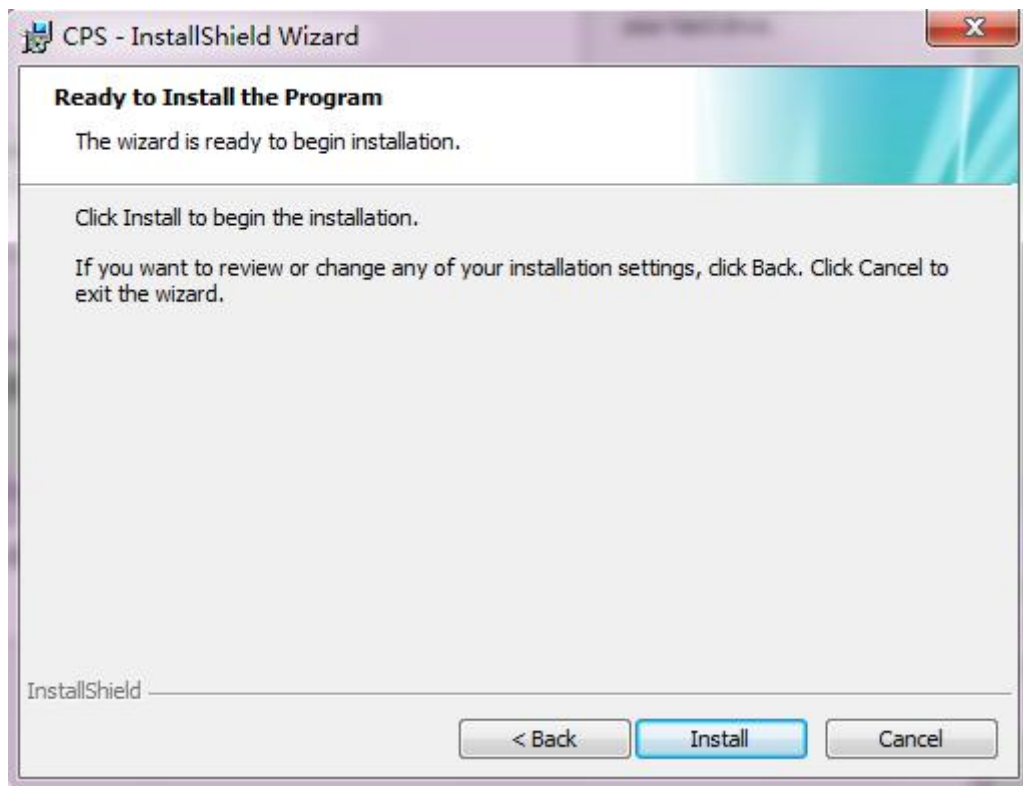

6) Wait the installation to complete. Click Finish to end CPS tools installation procedure.

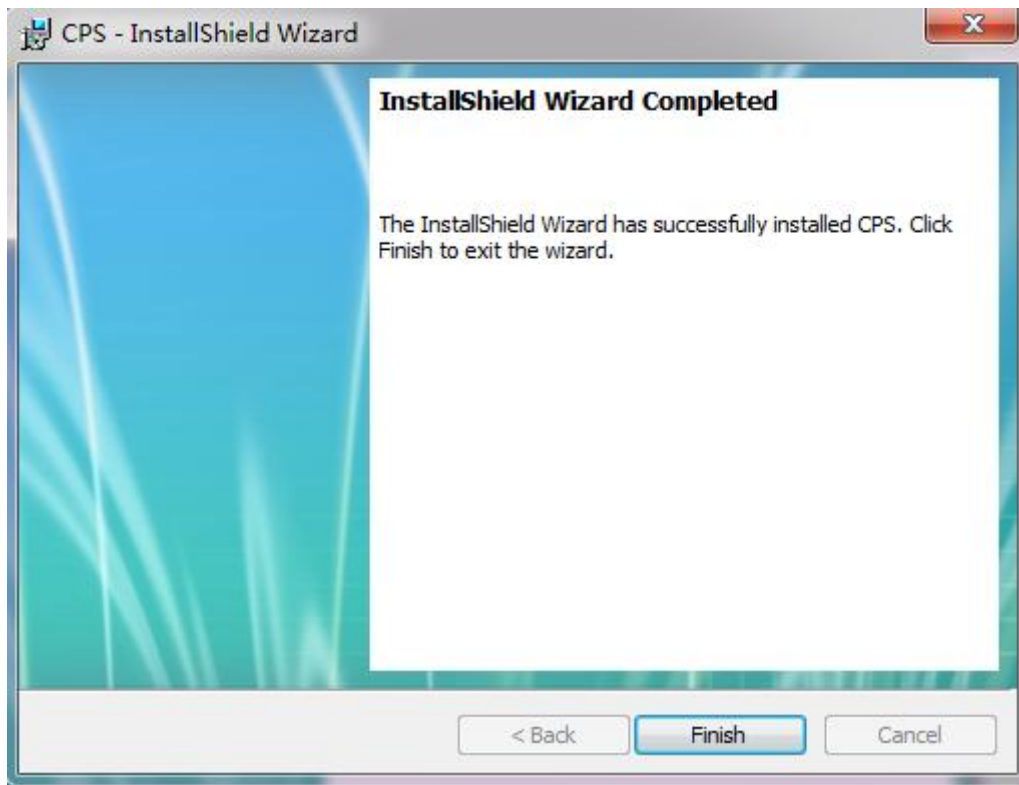

7) An icon will be on desktop after installation:



2. CPS Read

CPS read function can be started by shortcut key combination Ctrl + R or shortcut icon  to read data from the radio.

Precondition: The radio is power on in user mode.

1) Connect the radio with data cable, and connect data cable USB port to the computer, click CPS read to display the following interface;

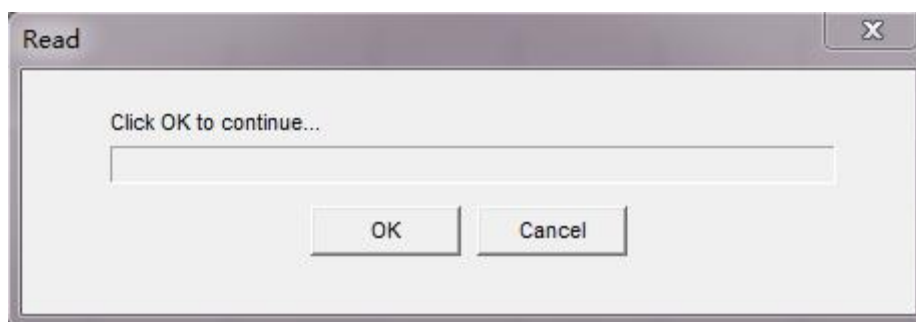

2) Click OK to continue, the radio displays reading and the CPS interface displays as below;

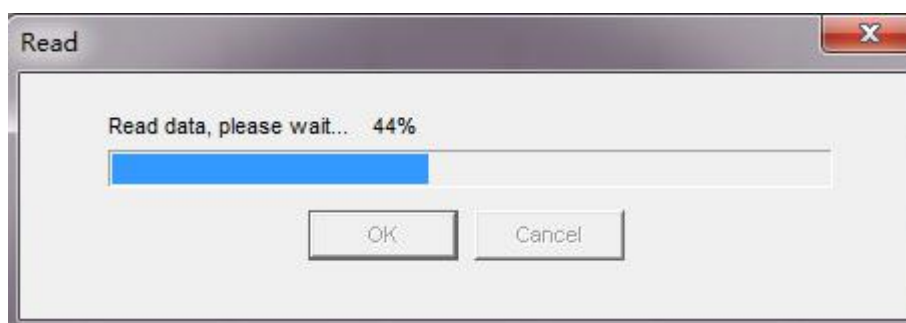

3) A pop-up message on the radio display will indicate read success after about 10 seconds, the radio goes back to home display. The CPS will indicate read success as below.



4) Click OK to complete CPS read.

3. CPS Write

CPS write function can be started by shortcut key combination Ctrl + W or shortcut icon  to write data into the radio.

Precondition: The radio database version and type code are consistent with the database version and type code of the data currently edited by the CPS software. The radio is power on in user

mode.

- 1) CPS software is used to configure data in template.
- 2) Connect the radio with data cable, and connect data cable USB port to the computer, click CPS write to display the following interface;

Write

DMR Conventional

Auto Increase

Radio Start ID 15

Written Count 0

Next ID 15

Click OK to continue...

OK Cancel

- 3) Click OK to continue, the radio displays writing and the CPS interface displays as below;

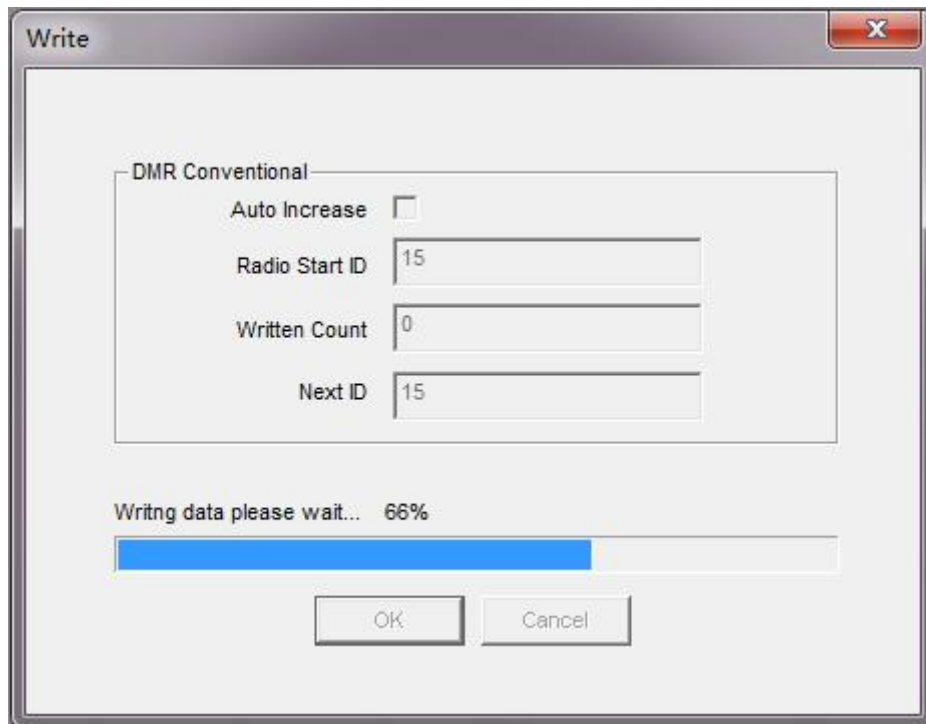

4) The radio automatically reboots after about 10 seconds. The CPS will indicate write success as below.



5) Click OK to complete CPS write.

4 Radio Disassemble Demonstration

4.1 Tools



①

②

③

④

⑤



⑥

SN	Item
1	Anti-static Glove
2	Anti-static Wrist Strap
3	Tweezers
4	Sockets
5	Screwdriver (Cross Screwdriver, Slotted Screwdriver, T6 Torx Screwdriver)
6	Soldering Iron

4.2 Procedure

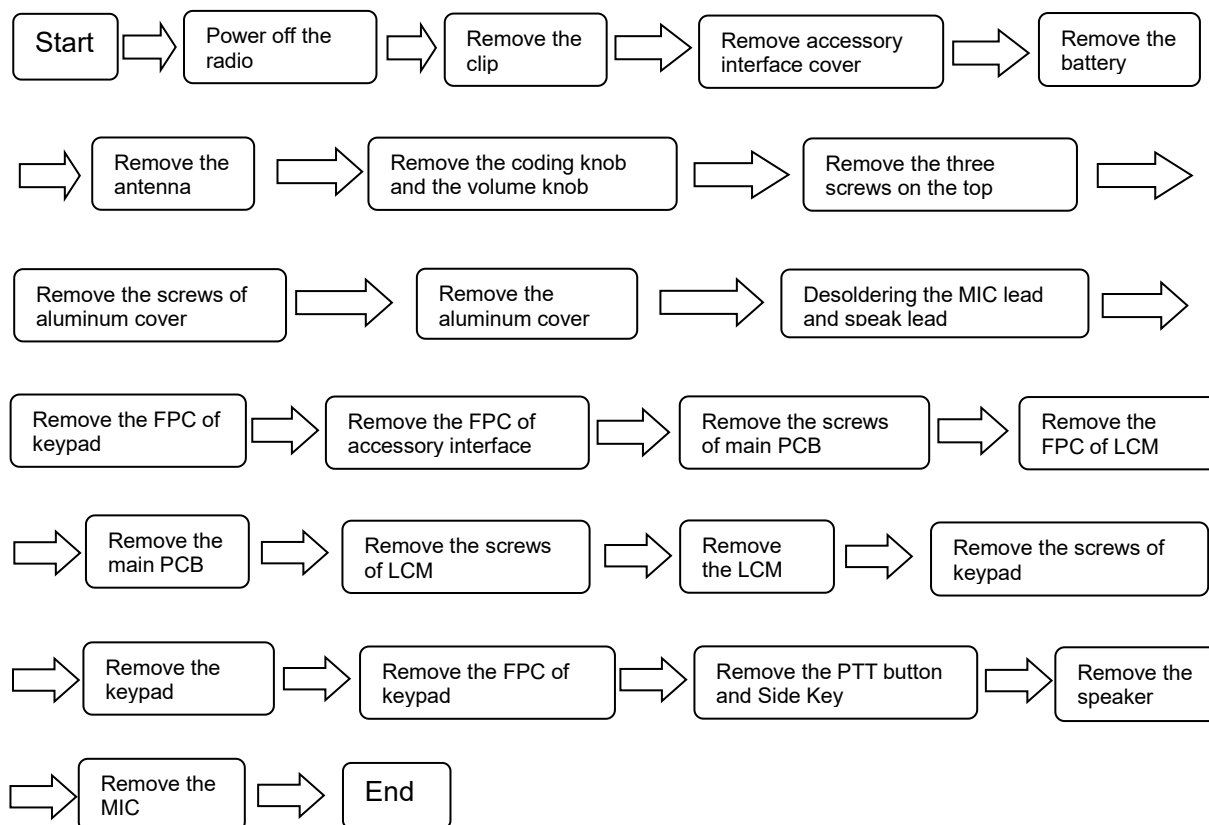

4.3 Disassemble Steps

Note: The following steps apply to PH660/DH630 Radio.

1. Rotate the volume knob count-clockwise to power off the radio;



2. Remove the two back cover/clip screws with cross screwdriver to remove the clip;



3. Remove the screw of accessory interface cover with slotted screwdriver to remove the accessory interface cover;



4. Push the battery lock to remove the battery;



5. Rotate the antenna count-clockwise to remove it;



6. Pull out the volume knob and coding knob;



7. Use the sockets to remove the antenna nut and switch nuts;



8. Use the T6 torx screwdriver to remove the screws of aluminum cover component to take out the aluminum cover component;



9. Use the soldering iron to disconnect speaker leads A and disconnect MIC leads B ;



10. Take out the FPC of accessory interface (A) and the FPC of keypad (B), be careful the obstruction of accessory interface board FPC and connector, pay attention to pull them out slowly not to break them with too much force.



11. Remove the six screws of main PCB with the cross screwdriver;

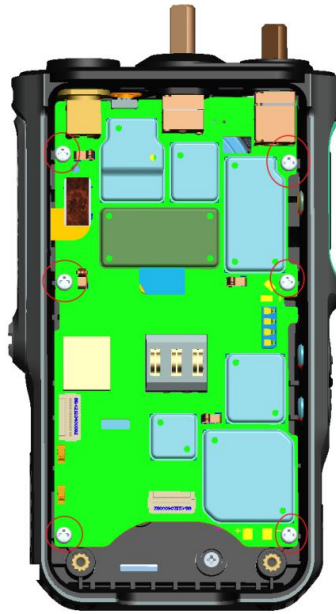

12. Lift the main PCB up obliquely to remove the LCD FPC (A), and take out the main PCB.

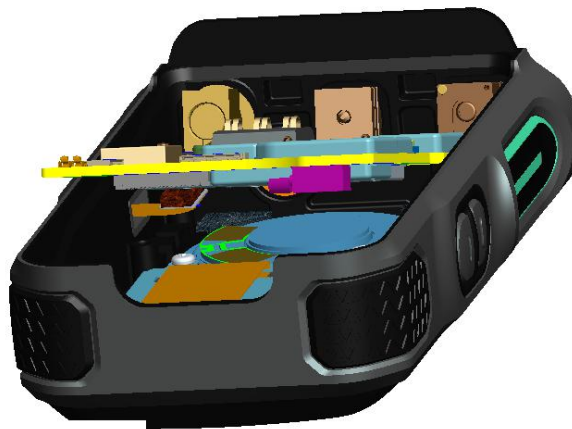

13. Remove the two screws (A and B) of LCD holder to take out the LCD component.

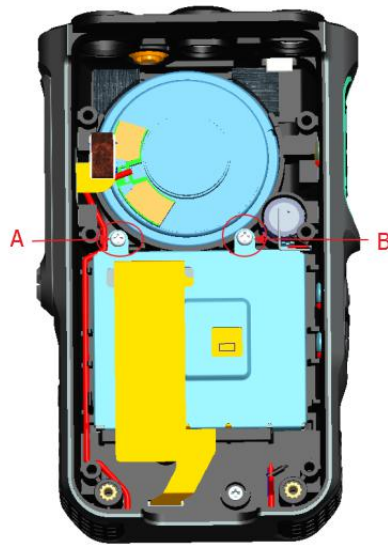

14. Remove the two screws (A and B) of keypad.

Note:

The two screws are sealed and can only be removed after breaking the sealing.

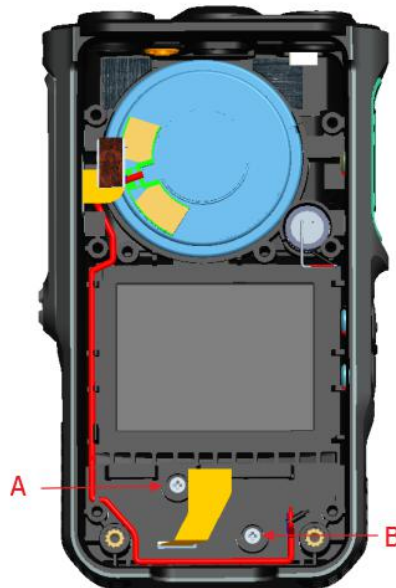

15. Remove the keypad.



16. To dismantle the keypad FPC, clean the white sealant around the FPC (A), note that the FPC back is stuck to the front cover, remove the FPC with the screwdriver;



17. Use the slotted screwdriver to open the buckles at the arrows to push out the PTT button (A), rubber (B), holder (C), side key (D and E), holder (F). The holder (C) and the rubber (D/E) can be

separated directly.

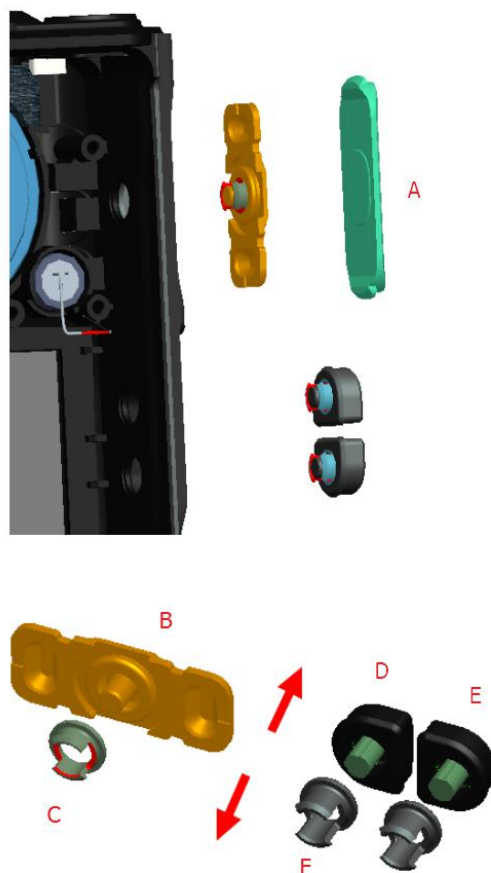
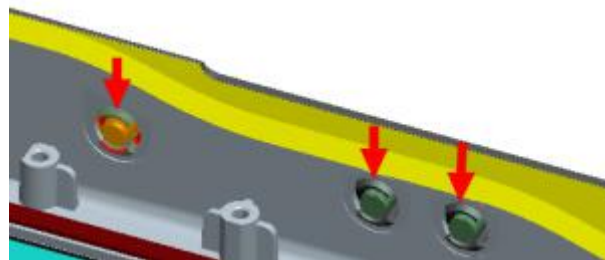

18. To dismantle the speaker, remove the white sealing (A) around the speaker, and use the screwdriver to take it out.

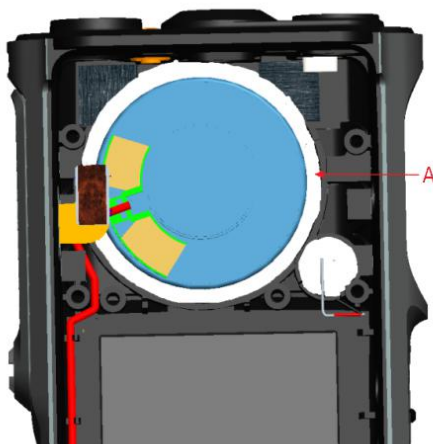

19. To dismantle the MIC, remove the white sealing (A) around the MIC, and use the screwdriver to take it out.



4.4 Assemble Steps

The assemble steps can refer to the disassemble steps and vice versa. Note that if the speaker and MIC are damaged and need to be replaced, first clean the white sealing around the speaker and MIC, then take them out with tweezers. When assembling the speaker, pay attention to its direction. Meanwhile the edge of the speaker needs to be glued (model TONSAN1527). The dispensing tool can use the 5ML syringe and the 1.0mm diameter needle. Leave it 4 hours after dispensing and then continue the remaining assembly after the glue is dry.

It is needed to organize the wiring when assembling and soldering the speaker and MIC. Note that the positive and negative electrodes on the main PCB. The red wire is soldered to the positive electrode and the black wire is soldered to the negative electrode. Do not burn the radio and the cover during soldering.

4.5 Components

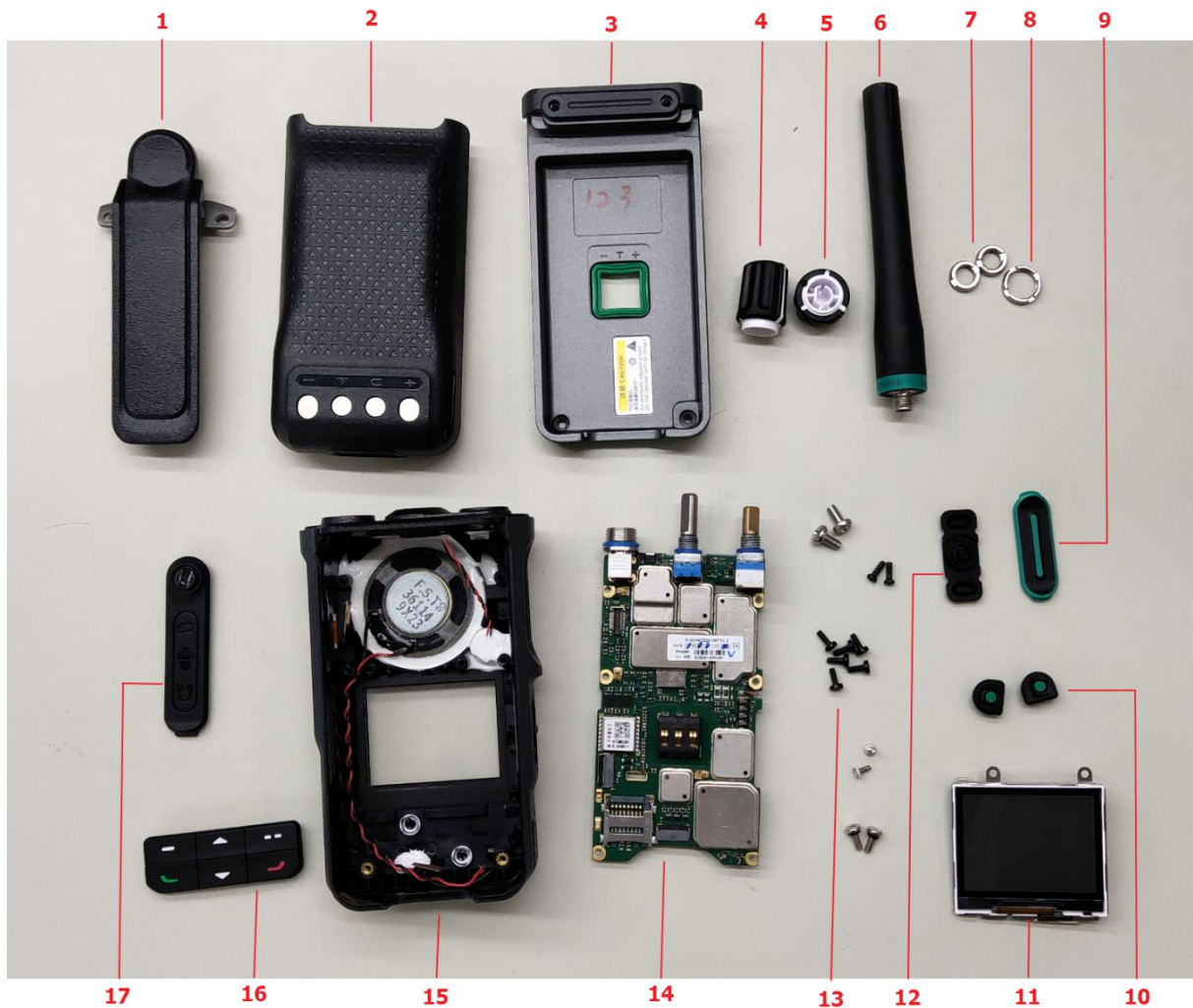

SN	Item	SN	Item
1	Clip	10	Side Key Rubber
2	Battery	11	LCD
3	Aluminum Cover	12	PTT Rubber
4	Coding Knob	13	Screw
5	Volume Knob	14	Main PCB

6	Antenna	15	Front Cover
7	Switch Nut	16	P+R keypad
8	Antenna Base Nut	17	Accessory Interface Cover
9	PTT Button Cover	18	

5 Hardware Pictures

5.1 Front of Main PCB

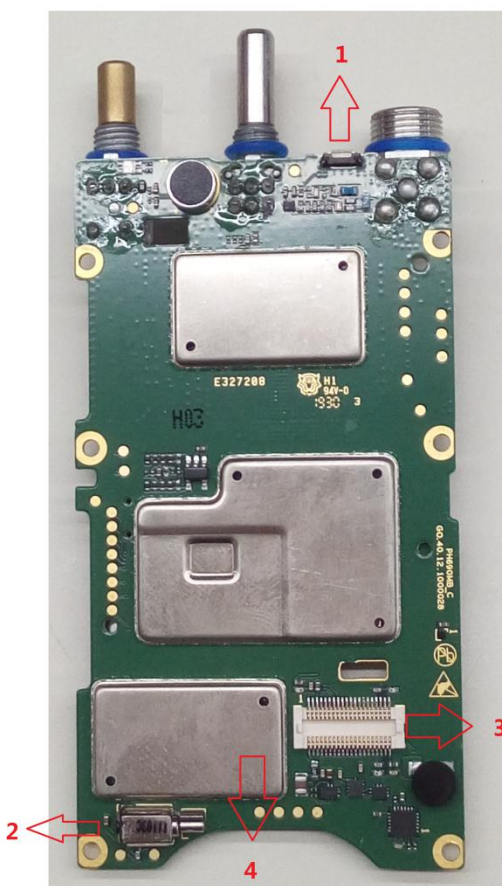

SN	Item
1	Emergency Button
2	Vibrator
3	LCD FPC plug

4	Bluetooth IC (none for low configuration)
---	---

5.2 Back of Main PCB

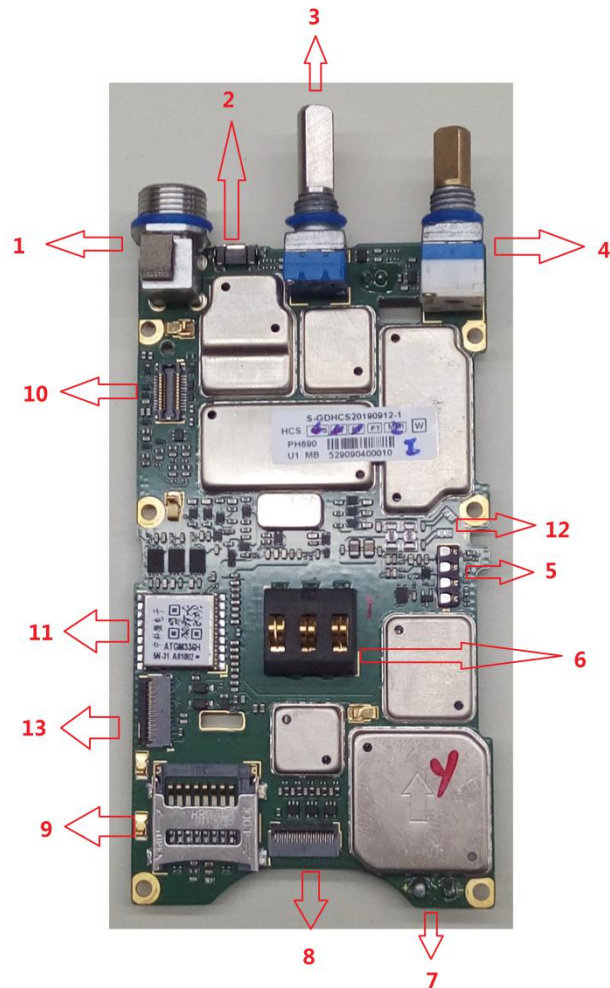

SN	Item
1	Main Antenna Connector
2	Emergency Button
3	Channel Knob
4	Power&Volume Knob
5	Side Key Interface (Connected to FPC and including PTT, GND, Up and Down from top to bottom)
6	Battery Connector
7	Speaker Soldering Point

8	Keypad FPC Plug
9	TF Card Slot
10	Accessory FPC Plug
11	GPS Module (none for low configuration)
12	MIC Soldering Point
13	Option Board FPC Plug

6 Troubleshooting Maintenance Flow

6.1 Structural Part Failure

For the failure of radio structural parts, please refer to 4.3 Disassemble Steps for replacement.

6.2 Battery Failure

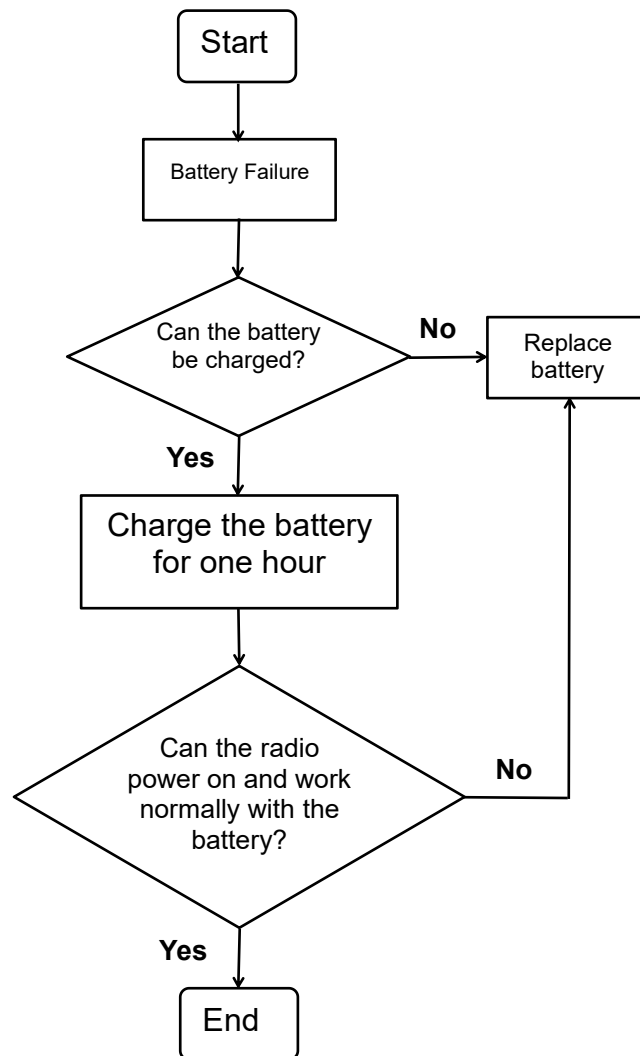

6.3 No Power On

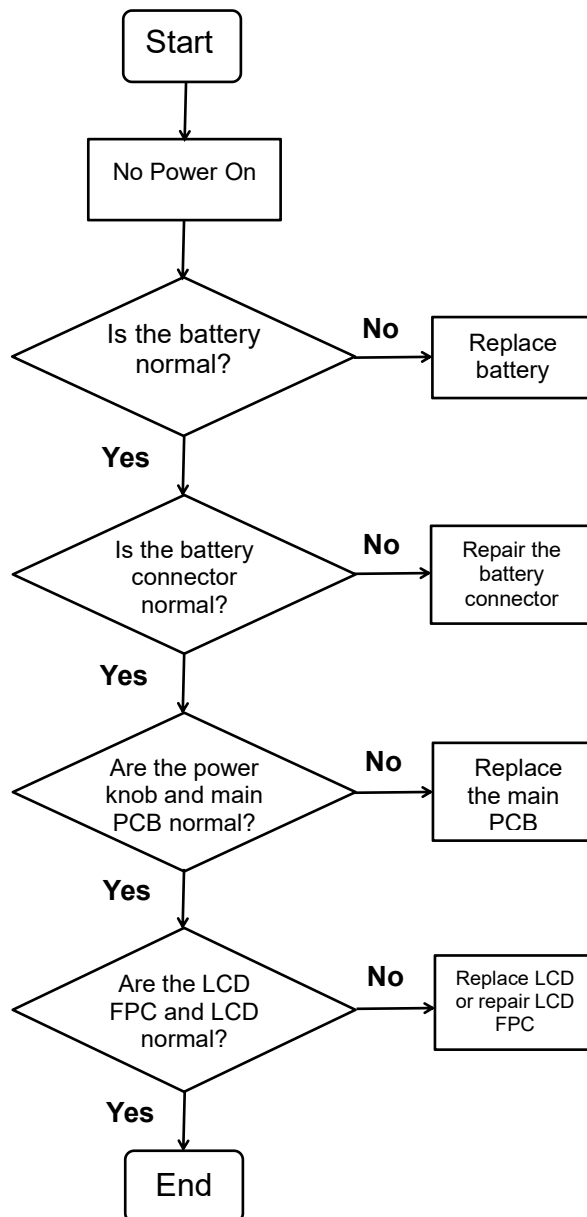

6.4 Radio Freeze or Power Off Automatically

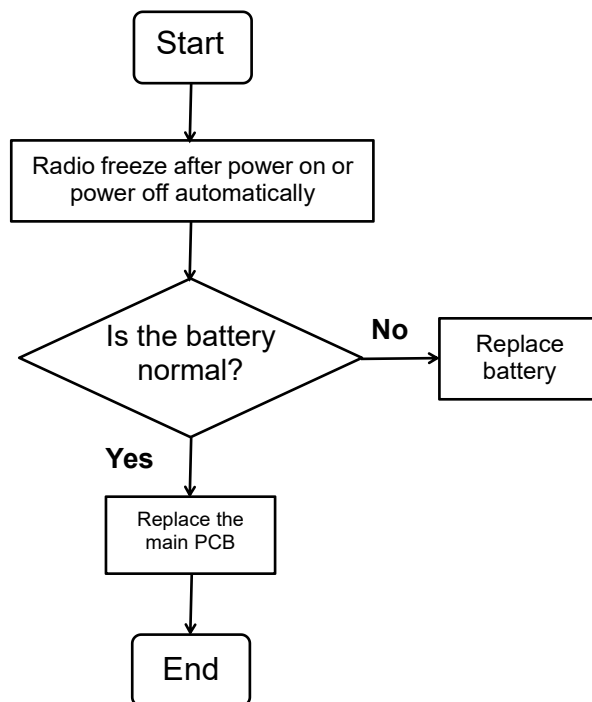

6.5 Charge Failure

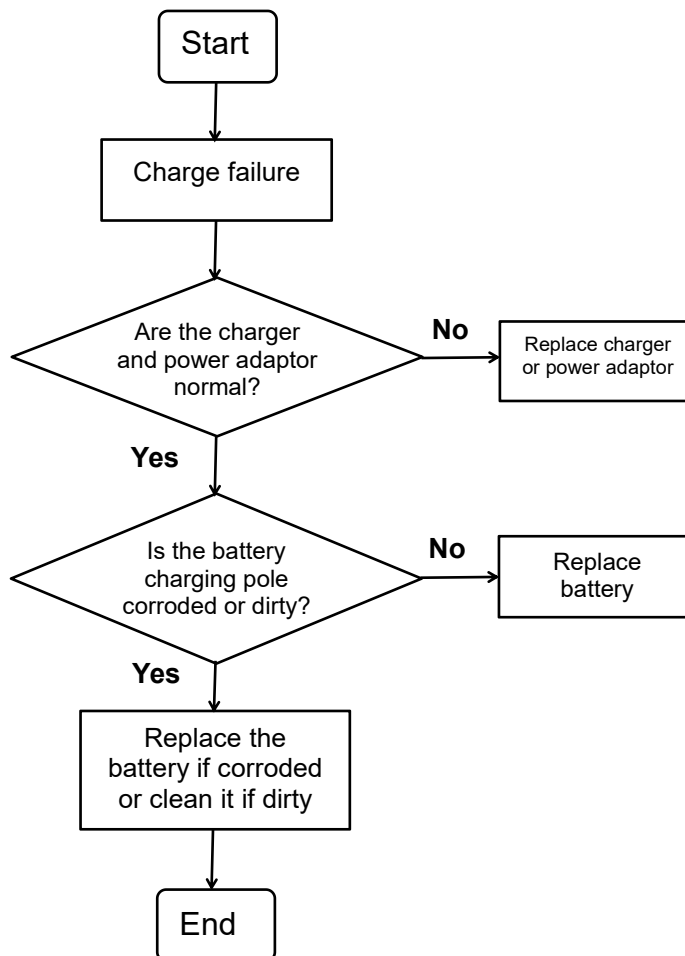

6.6 No Voice (MIC) Failure

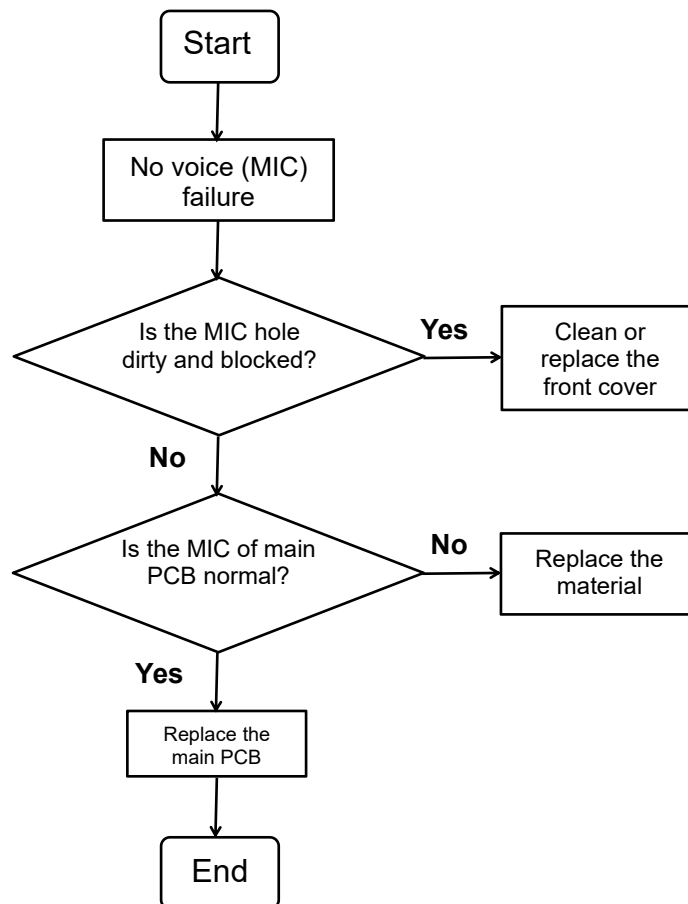

6.7 No Sound (Speaker) Failure

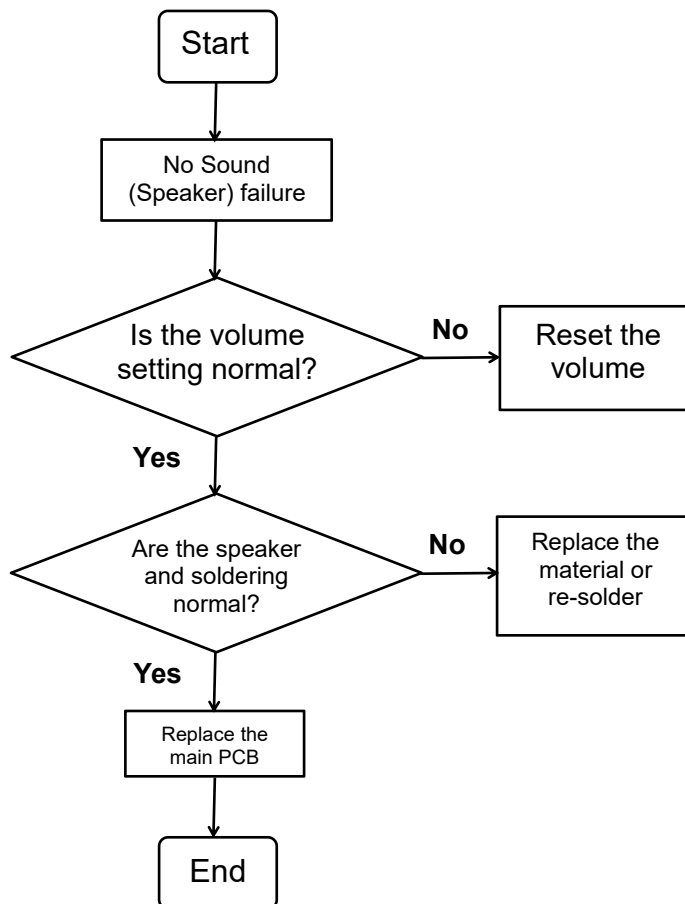

6.8 Side Key Failure

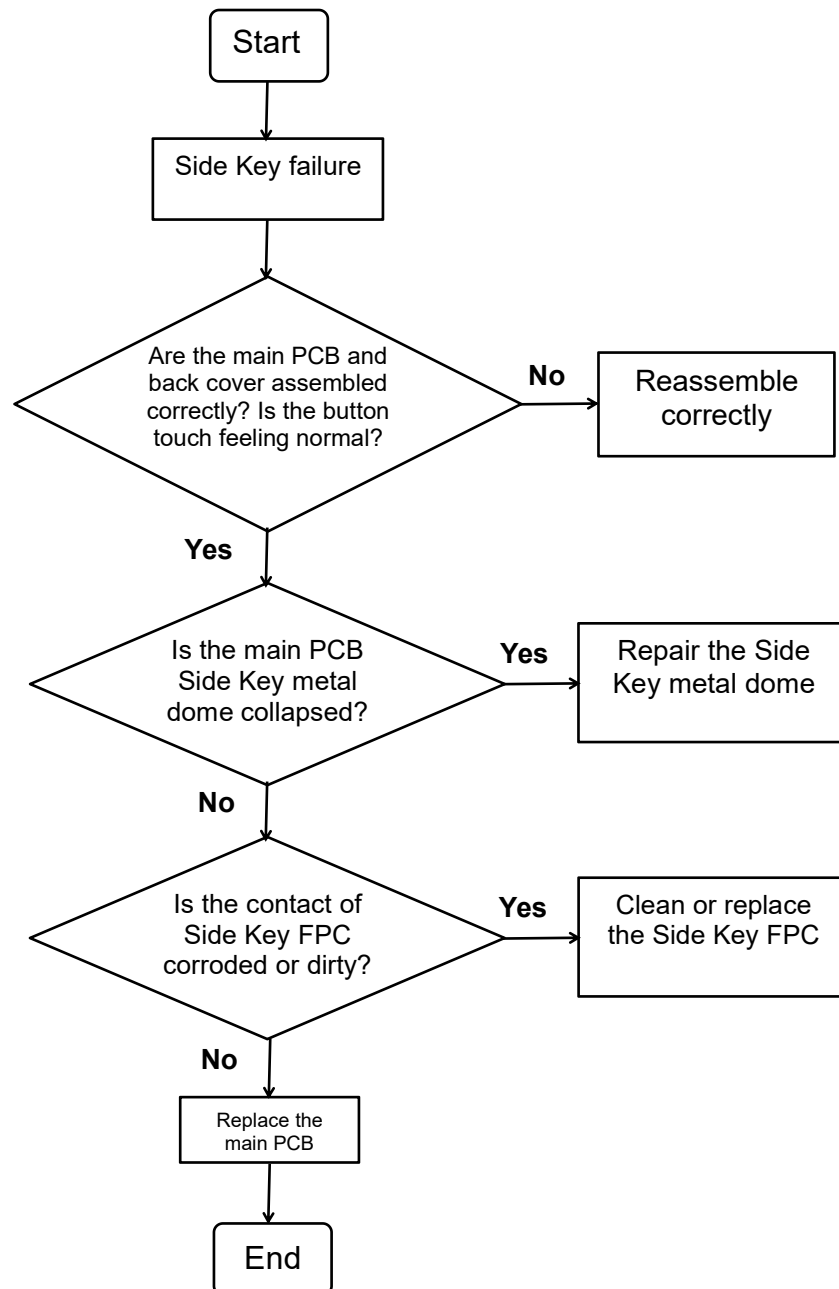

6.9 Keypad Failure

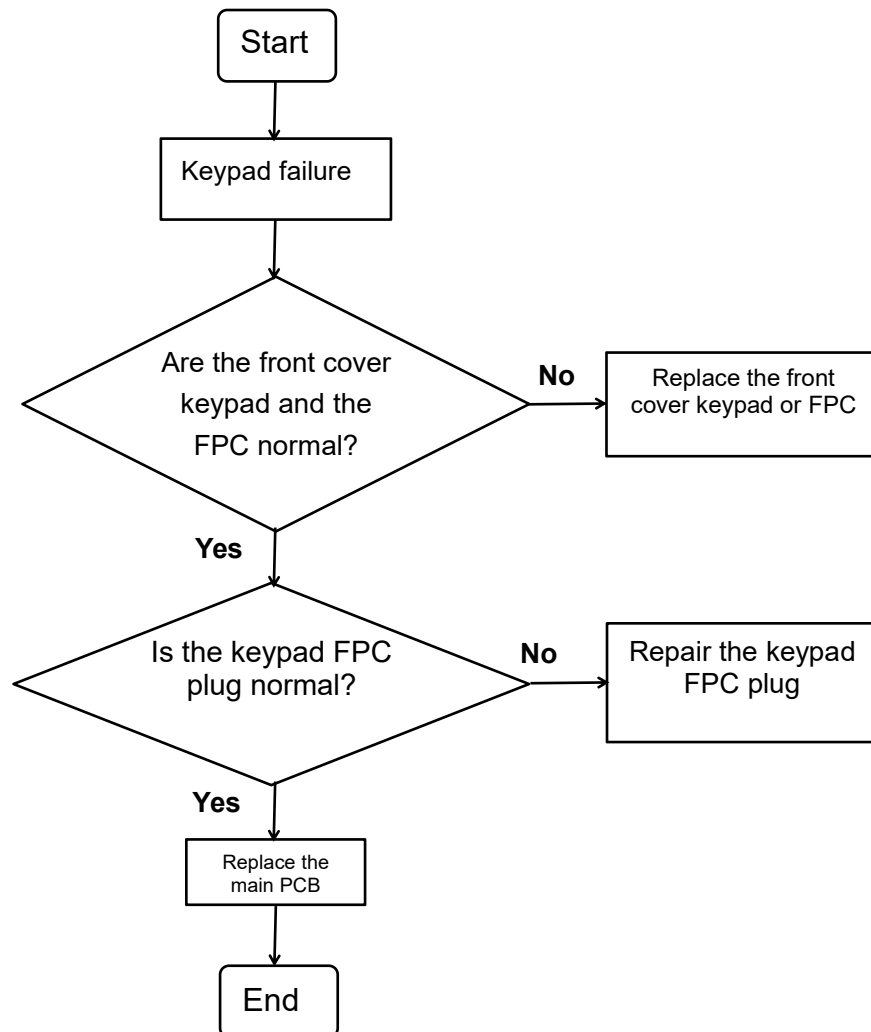

6.10 Accessory Failure

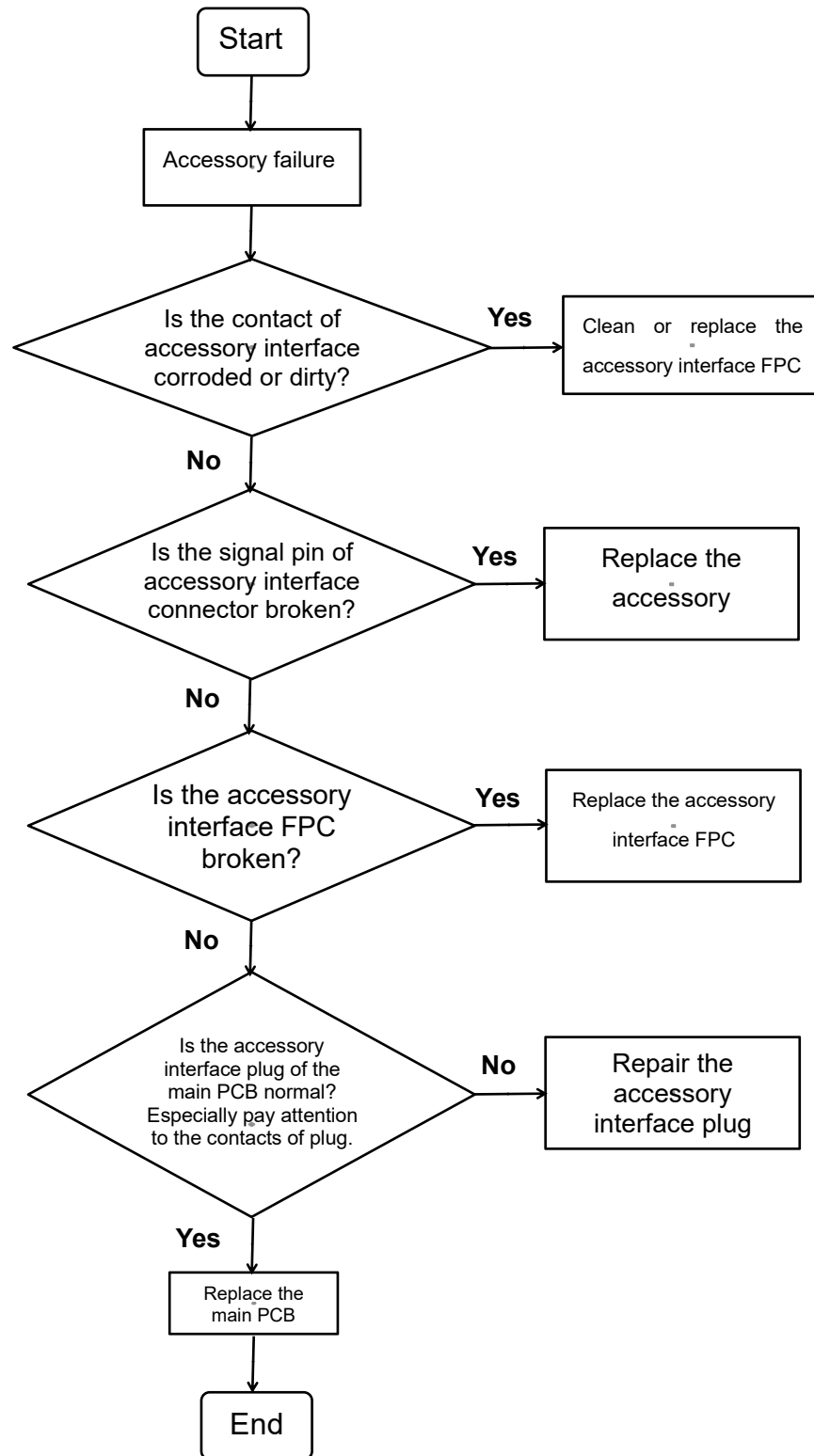

6.11 TF Missing

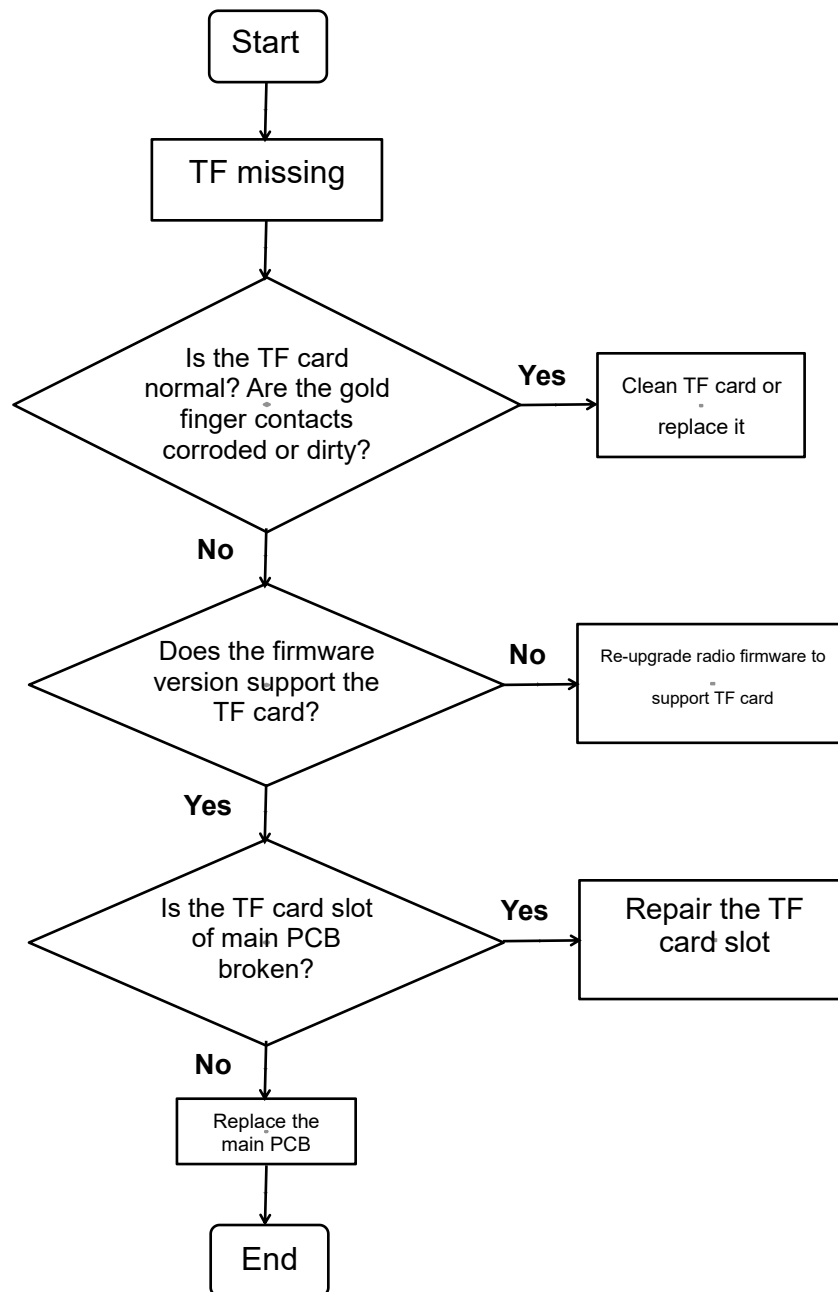

7 Check After Maintenance

7.1 Check Latest Firmware Version and Device Information

Please refer to 2.2 Check Firmware Version and Device Information.

7.2 Function Check

After the radio maintenance, check if every function is available. Follow the steps:

1. After assemble the radio, check if all screws and components are installed, there should be no extra screws.
2. Check if the touch feeling of button is normal for PTT button, up button, down button and top button. Check if the volume knob and coding knob operate normally.
3. Install the battery and power on the radio to check that radio can power on normally and LED indicator is normal.
4. Check if the keypad is normal and the key can respond normally to touch.
5. Connect the data cable to check if the radio can CPS read and write normally.
6. Turn coding knob to adjust radio frequency and set work mode to the same as another normal radio, and make a voice call test to check if the call can be sent, received, and if the voice is normal.
7. Finish checking.